

# IXP Impactor™

Two Directional Impactable  
Fiberglass Bi-Parting  
Cooler/Freezer Door System

# Data Sheet

Model IXP 1000



OPTIONAL  
BREAKAWAY PANELS

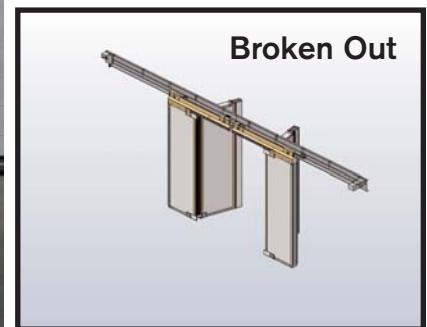
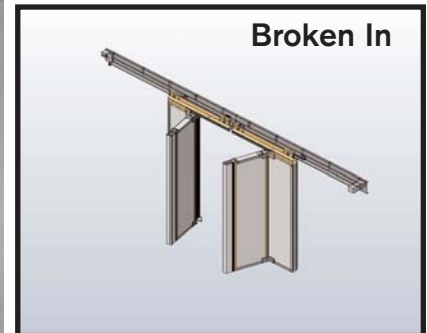

Available in manual operation and without breakaway panel.

## FEATURES

- Standard high dual speed operation (96"/sec open - 48"/sec close).
- Strong impactable panels with a full 90 degree swing capability in both directions.
- High impact composite reinforced panel material.
- 4" fully insulated impactable panel.
- Standard stainless steel header and rail with epoxy coated roller trucks.
- Emergency egress (optional).
- Integrated and fully protected self-regulating heater system.
- No floor hardware.
- Steel reinforced polyurethane drive belt.
- No reversing edge extrusions to damage.
- Integrated cut-off switch to stop door movement if panels are impacted.
- Standard NEMA 4 fiberglass control box.



## Model IXP 1000

### DESIGN AND CONSTRUCTION

#### DOOR SIZES

- Minimum: 7' x 6'
- Maximum: 12' x 15'
- *Other sizes available - consult factory.*

#### PANEL CONSTRUCTION

- Sealed and unitized design.
- High impact fiberglass reinforced composite shells.
- 1/8" thick high impact fiberglass composite angles along all vertical panel edges.
- USDA approved material.
- Full perimeter adjustable gaskets.

#### BREAKAWAY PANEL CONSTRUCTION (Optional)

- Full impact capable panels allow for a 90° swing capability in both directions.
- 1/8" thick, 48" high impact capable polymer plating on both sides of breakaway panels.
- Panels provided with breakaway/reset assist.
- Automatic breakaway power cut-off switch.

#### TRACK CONSTRUCTION

- Stainless steel header and rail.
- USDA approved roller trucks and steel hardware.
- Nylon rollers with lubed for life bearings.
- Steel reinforced polyurethane drive belt.

#### OPERATION

- Electric:
  - 96" ips\* opening
  - 48" ips closing
  - \*Inches per second.
- PLC (Programmable Logic Controls).
- VFD (Variable Frequency Drive).
- 208/230/460 volt, 3 phase power required.
- Manual.

### ELECTRIC SYSTEM

- High output, high torque electric drive system powered by 1-3/4 hp totally enclosed motor.
- NEMA-4 fiberglass control box.

### PERFORMANCE FEATURES

- Door panel reversing for instant stop/reverse through main control box.
- Manual operation.
- Emergency egress capable (optional).

### INSULATION

- 4" thick closed cell, R25.

### WARRANTY

- 1 year limited warranty on parts and labor.

### OPTIONS

- Non-breakaway panels construction.
- Emergency egress.
- Jamb capping.
- Mirror image header.
- Wash down grade operator.
- Pedestrian opening (remote push button station for partial opening - automatic time delay close. All adjustable).
- Extra pull cord or single push button activation (2-pull cord standard).
- Photoeye activation or reversing photoeye.
- Radio control activation.
- Loop detector system activation.
- Motion sensors.
- Presence sensors.
- Pre-announce to close kit (light/alarm/or combo).
- UNI-directional sensors.
- Sensor mounting brackets.
- Strobe lights.
- Shroud for rail.
- Windows-2 lite.
- Future power.

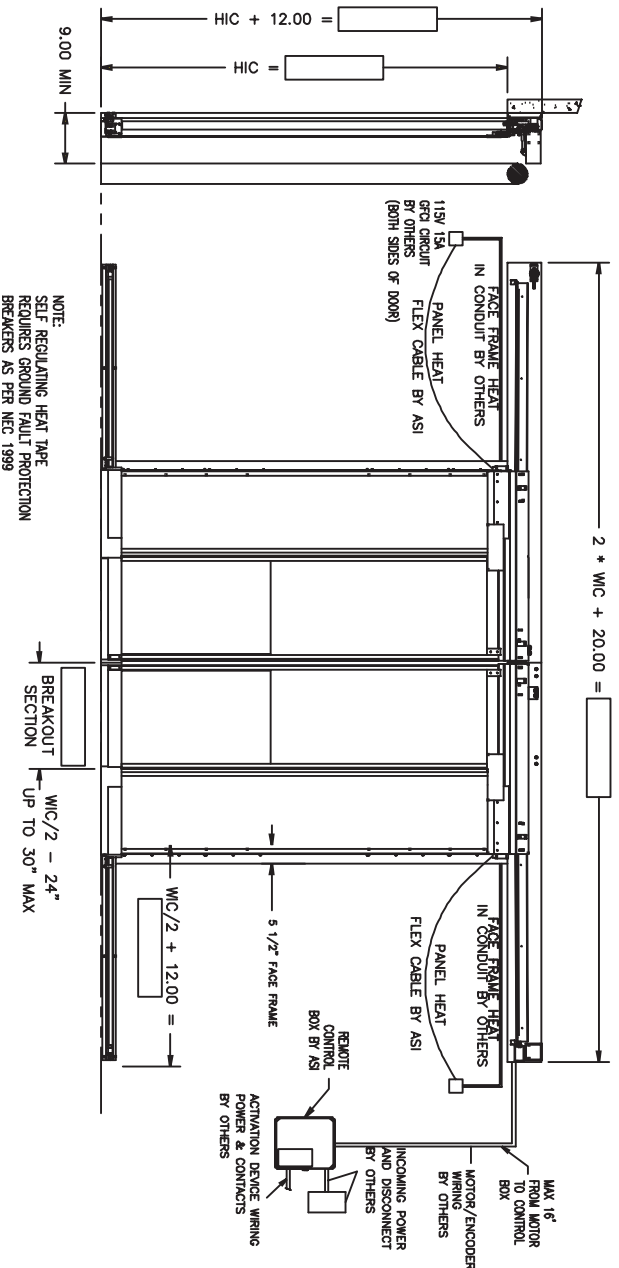
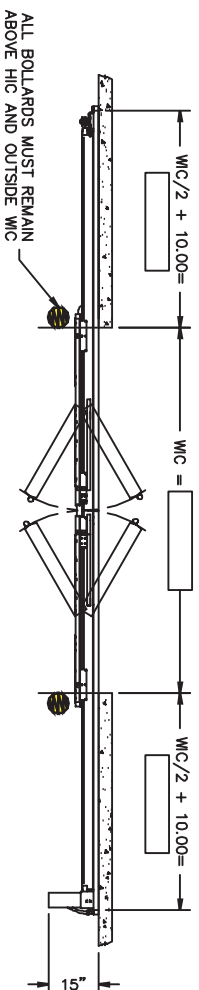

NOTE:  
SELF REGULATING HEAT TAPE  
REQUIRES GROUND FAULT PROTECTION  
BREAKERS AS PER NEC 1999

WIC/2 - 24"  
UP TO 30" MAX

WIC/2 + 12.00 =

Patent Pending

For complete Architectural Specifications  
contact ASI or visit [www.asidoors.com](http://www.asidoors.com)

# ASI Technologies, Inc.



5848 N. 95th Court • Milwaukee, WI 53225 • (414) 464-6200 • (800) 558-7068 • FAX: (414) 464-9863 • [www.asidoors.com](http://www.asidoors.com)

Consistent with our policy of continued product improvement, we reserve the right to change product specifications without notice or obligation.

IXP 1000 S/2006R

©2004, ASI TECHNOLOGIES, INC. • PRINTED IN U.S.A.